

- Wide Input Voltage Range 18V to 40V
- 82% Efficiency
- 1500 VDC Isolation
- Small Footprint 1.45" x 1.64"
- Low Profile 0.315" (8mm)
- Adjustable Output
- Short Circuit Protection
- Over Temperature Shutdown
- UL1950 Recognized
- CSA 22.2 950 Certified
- Designed to Meet EN60950

The PT4140 series of 24V Isolated DC-DC Converters advance the state-of-the-art for board-mounted converters by employing 850kHz switching frequencies, planar magnetics, and surface-mount construction. These regulators are pin-compatible with Power Trends' popular PT4100 series, and offer an improved power density (25 Watts/in<sup>3</sup>) plus output voltage adjustment. They are designed for Telecom, Industrial, Computer, Medical, and other distributed power applications that require input-to-output isolation.

**Standard Application**

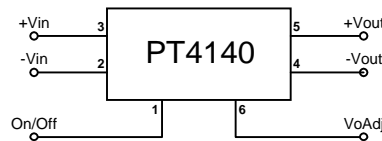

**Pin-Out Information**

Pin	Function
1	Remote <sup>(3)</sup> ON/OFF
2	-V <sub>in</sub>
3	+V <sub>in</sub>
4	-V <sub>out</sub>
5	+V <sub>out</sub>
6	V <sub>out</sub> Adjust <sup>(3)</sup>

**Specifications**

Characteristics (T <sub>a</sub> = 25°C unless noted)	Symbols	Conditions	PT4140 SERIES			Units
			Min	Typ	Max	
Output Current	I <sub>o</sub>	Over V <sub>in</sub> range V <sub>o</sub> ≤ 3.3V V <sub>o</sub> = 5V V <sub>o</sub> = 12V	0 0 0	— — —	5.0 (2) 4.0 (2) 1.6 (2)	A
On/Off Standby Current	I <sub>in standby</sub>	V <sub>in</sub> = 24V, Pin 1 = -V <sub>in</sub>	—	7	10	mA
Short Circuit Current	I <sub>sc</sub>	V <sub>in</sub> = 24V	—	2xI <sub>o max</sub>	—	A
Inrush Current	I <sub>ir</sub> t <sub>ir</sub>	V <sub>in</sub> = 24V @ I <sub>o max</sub> On start-up	— —	1.0 1.0	— —	A mSec
Input Voltage Range	V <sub>in</sub>	Over I <sub>o</sub> Range	18.0	24.0	40.0	VDC
Output Voltage Tolerance	ΔV <sub>o</sub>	Over V <sub>in</sub> Range T <sub>a</sub> = -40°C to +85°C	—	±1.0	±2.0	%V <sub>o</sub>
Line Regulation	Reg <sub>line</sub>	Over V <sub>in</sub> range @ I <sub>o max</sub>	—	±0.5	±1.0	%V <sub>o</sub>
Load Regulation	Reg <sub>load</sub>	10% to 100% of I <sub>o max</sub>	—	±0.5	±1.0	%V <sub>o</sub>
V <sub>o</sub> Ripple/Noise	V <sub>n</sub>	V <sub>in</sub> =24V, I <sub>o</sub> =I <sub>o max</sub> , V <sub>o</sub> ≥ 5V V <sub>in</sub> =24V, I <sub>o</sub> =I <sub>o max</sub> , V <sub>o</sub> < 5V	— —	1.0 50	— —	%V <sub>o</sub> mV <sub>pp</sub>
Transient Response	t <sub>tr</sub>	50% load change, V <sub>o</sub> ≥ 5V V <sub>o</sub> over/undershoot	— —	100 3.0	— —	μSec %V <sub>o</sub>
Efficiency	η	V <sub>in</sub> =24V, I <sub>o</sub> =5A, V <sub>o</sub> =3.3V V <sub>in</sub> =24V, I <sub>o</sub> =4A, V <sub>o</sub> =5V V <sub>in</sub> =24V, I <sub>o</sub> =1.6A, V <sub>o</sub> =12V	— — —	78 82 83	— — —	%
Switching Frequency	f <sub>o</sub>	Over V <sub>in</sub> and I <sub>o</sub> , V <sub>o</sub> ≤ 5V V <sub>o</sub> > 5V	800 600	850 650	900 700	kHz
Maximum Operating Temperature Range	T <sub>a</sub>	V <sub>in</sub> = 24V with 200 LFM airflow	-40	—	+85 (2)	°C
Storage Temperature	T <sub>s</sub>	—	-40	—	+110	°C
Mechanical Shock	—	Per Mil-Std-883D, method 2002.3, 1mS, half-sine, mounted to a fixture	—	500	—	G's
Mechanical Vibration	—	Per Mil-Std-883D, method 2007.2, 20-2000Hz, soldered in a PC board	—	15	—	G's
Weight	—	—	—	15	—	grams
Isolation	—	—	1500	—	—	V
Capacitance	—	—	—	1100	—	pF
Resistance	—	—	10	—	—	MΩ
Flammability	—	Materials meet UL 94V-0	—	—	—	—
Remote On/Off	On Off	Open or 2.5 to 7.0 VDC above -V <sub>in</sub> Short or 0 to 0.8 VDC above -V <sub>in</sub>	—	—	—	—

**Notes:** (1) The maximum output current limits the power rating of the following devices to less than 20W:-  
PT4141 = 16.5W; PT4148 = 12.5W.

(2) See Safe Operating Area curves or contact the factory for the appropriate derating.  
(3) See Application Notes at end of section.

**Ordering Information**

- (1) **PT4141**□ = 3.3V/5A
- PT4142**□ = 5.0V/4A
- PT4143**□ = 12.0V/1.6A
- PT4144**□ = 15.0V/1.3A
- (1) **PT4148**□ = 2.5V/5A

**PT Series Suffix (PT1234X)**

**Pin Configuration**

Horizontal Through-Hole	<b>A</b>
Horizontal Surface Mount	<b>C</b>

(For dimensions and PC board layout, see Package Style 710.)

**\* Note:** This product is the subject of one or more patents. Other patents pending.

20 Watt 24V Input Isolated DC-DC Converter

PT4141, 3.3 VDC (See Note A)

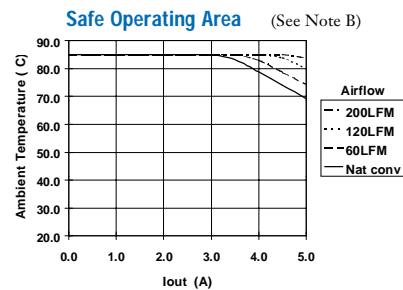
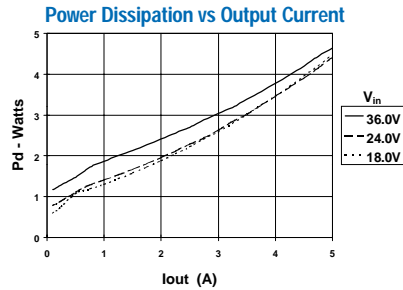
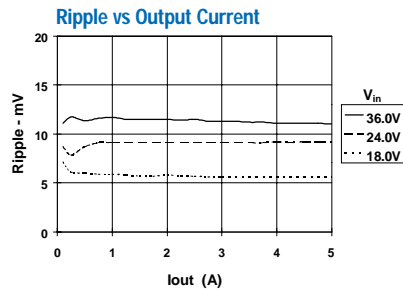
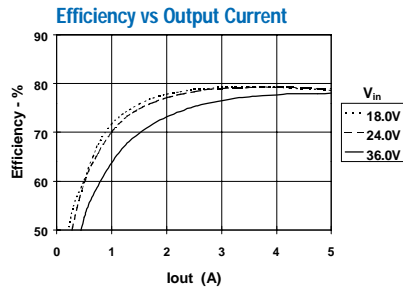

PT4142, 5.0 VDC (See Note A)

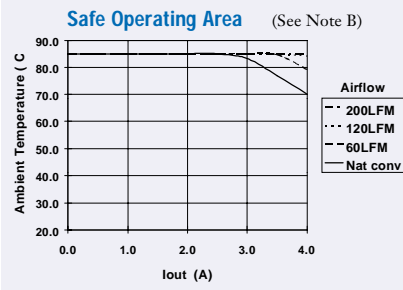
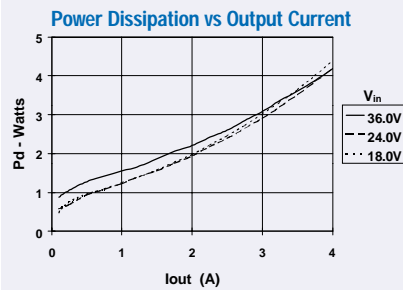
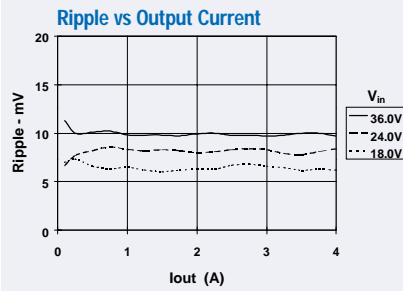
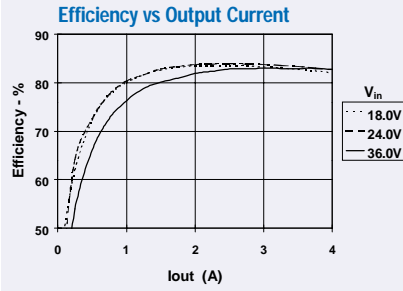

PT4143, 12.0 VDC (See Note A)

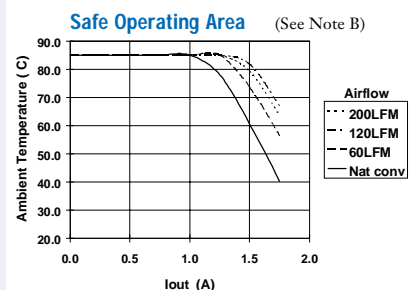
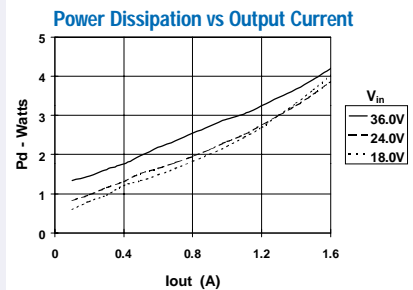
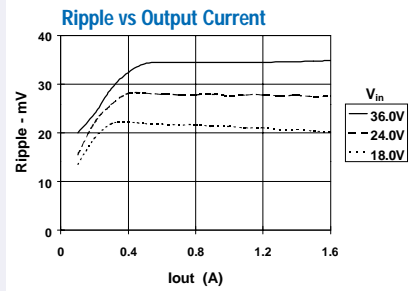
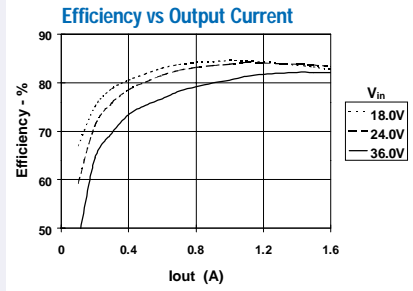

Note A: Characteristic data has been developed from actual products tested at 25°C. This data is considered typical data for the Converter.  
 Note B: Safe Operating Area curves represent conditions at which internal components are at or below manufacturer's rated operating temperatures.

## PT4120/4140 Series

### Adjusting the Output Voltage of the PT4120/PT4140 Series of Isolated DC-DC Converters

The factory pre-set output voltage of Power Trends' PT4120 and PT4140 series of isolated DC-DC converters may be adjusted within a nominal  $\pm 10\%$  range. Adjustment is made from the secondary side of the regulator<sup>1</sup> with a single external resistor. For the input voltage range specified in the data sheet Table 1 gives the allowable adjustment range for each model, as  $V_o$  (min) and  $V_o$  (max).

**Adjust Up:** An increase in the output voltage is obtained by adding a resistor, R2 between pin 6 ( $V_o$  adjust), and pin 4 ( $-V_{out}$ ).

**Adjust Down:** Add a resistor (R1), between pin 6 ( $V_o$  adjust) and pin 5 ( $+V_{out}$ ).

Refer to Figure 1 and Table 2 for both the placement and value of the required resistor, (R1) or R2.

#### Notes:

- The PT4120 and PT4140 series of dc-dc converters incorporate isolation between the  $V_{in}$  and  $V_o$  terminals. Adjustment of the output voltage is made to the regulation circuit on the secondary or output side of the converter.
- The maximum rated output power for this series is 20W. An increase in the output voltage may therefore require a corresponding reduction in the maximum output current (see Table 1). The revised maximum output current must be determined as follows:-

$$I_o(\text{max}) = \frac{20}{V_a} \text{ A, or } 5\text{A, whichever is less.}$$

Where  $V_a$  is the adjusted output voltage.

- Use only a single 1% resistor in either the (R1) or R2 location. Place the resistor as close to the ISR as possible.
- Never connect capacitors to  $V_o$  adjust. Any capacitance added to the  $V_o$  adjust control pin will affect the stability of the ISR.

The values of (R1) [adjust down], and R2 [adjust up], can also be calculated using the following formulas.

$$(R1) = \frac{K_o(V_a - V_r)}{V_r(V_o - V_a)} - R_s \quad \text{k}\Omega$$

$$R2 = \frac{K_o}{(V_a - V_o)} - R_s \quad \text{k}\Omega$$

Where  $V_o$  = Original output voltage  
 $V_a$  = Adjusted output voltage  
 $V_r$  = Reference voltage (Table 1)  
 $K_o$  = Multiplier constant (Table 1)  
 $R_s$  = Series resistance (Table 1)

Figure 1

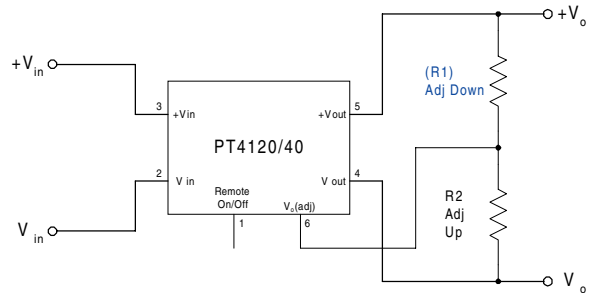

Table 1

#### DC-DC CONVERTER ADJUSTMENT RANGE AND FORMULA PARAMETERS

Series Pt #						
48V Bus	PT4127	PT4128	PT4121	PT4122	PT4123	PT4124
24V Bus	—	—	PT4141	PT4142	PT4143	PT4144
Max Current <sup>2</sup>	5A	5A	5A	4A	1.6A	1.3A
$V_o(\text{nom})$	1.8	2.5	3.3	5.0	12.0	15.0
$V_a(\text{min})$	1.62.0	2.25	2.95	4.5	10.8	13.5
$V_a(\text{max})$	1.98	2.75	3.65	5.5	13.2	16.5
$V_r$	1.224	1.224	1.224	2.5	2.5	2.5
$K_o$ (V·k $\Omega$ )	69.7	64.2	69.3	125.2	139.8	137.6
$R_s$ (k $\Omega$ )	110.0	187.0	187.0	187.0	110.0	90.9

PT4120/4140 Series

Table 2

DC-DC CONVERTER SERIES ADJUSTMENT RESISTOR VALUES

Series Pt #							
48V Bus	PT4127	PT4128	PT4121	PT4122	PT4123	PT4124	
24V Bus	—	—	PT4141	PT4142	PT4143	PT4144	
V <sub>o</sub> (nom)	1.8Vdc	2.5Vdc	3.3Vdc	5.0Vdc	12.0Vdc	15.0Vdc	
V <sub>a</sub> (req'd)				V <sub>a</sub> (req'd)			
1.65	(51.7)kΩ			4.5	(12.6)kΩ	10.8 (276.0)kΩ	
1.68	(106.0)kΩ			4.55	(40.3)kΩ	11.0 (365.0)kΩ	
1.7	(161.0)kΩ			4.6	(75.0)kΩ	11.2 (497.0)kΩ	
1.72	(243.0)kΩ			4.65	(120.0)kΩ	11.4 (719.0)kΩ	
1.75	(489.0)kΩ			4.7	(179.0)kΩ	11.6 (1.16)MΩ	
1.8				4.75	(262.0)kΩ	11.8	
1.85	1.28MΩ			4.8	(387.0)kΩ	12.0	
1.88	761.0kΩ			4.85	(595.0)kΩ	12.2 588.0kΩ	
1.9	587.0kΩ			4.9	(1.01)MΩ	12.4 239.0kΩ	
1.92	471.0kΩ			4.95		12.6 123.0kΩ	
1.95	255.0kΩ			5.0		12.8 64.6kΩ	
2.25		(25.9)kΩ		5.05		13.0 29.7kΩ	
2.3		(92.2)kΩ		5.1	1.06MΩ	13.2 6.4kΩ	
2.35		(203.0)kΩ		5.15	645.0kΩ	13.5 (312.0)kΩ	
2.4		(423.0)kΩ		5.2	437.0kΩ	13.6 (345.0)kΩ	
2.45		(1.09)MΩ		5.25	312.0kΩ	13.8 (427.0)kΩ	
2.5				5.3	229.0kΩ	14.0 (542.0)kΩ	
2.55		1.09MΩ		5.35	169.0kΩ	14.2 (713.0)kΩ	
2.6		449.0kΩ		5.4	125.0kΩ	14.4 (1.0)MΩ	
2.65		237.0kΩ		5.45	90.2kΩ	14.6 (1.57)MΩ	
2.7		131.0kΩ		5.5	62.4kΩ	14.8	
2.75		67.5kΩ				15.0	
2.95			(90.2)kΩ			15.2 597.0kΩ	
3.0			(146.0)kΩ			15.4 253.0kΩ	
3.05			(224.0)kΩ			15.6 138.0kΩ	
3.1			(340.0)kΩ			15.8 81.0kΩ	
3.15			(535.0)kΩ			16.0 46.6kΩ	
3.2			(924.0)kΩ			16.5 0.8kΩ	
3.25			(2.09)MΩ				
3.3							
3.35			1.19MΩ				
3.4			502.0kΩ				
3.45			272.0kΩ				
3.5			157.0kΩ				
3.55			88.6kΩ				
3.6			42.6kΩ				
3.65			9.8kΩ				

R1 = (Blue)

R2 = Black

## PT4120/4140 Series

### Using the Remote On/Off Function on the PT4120/PT4140 Series of Isolated DC-DC Converters

For applications requiring output voltage on/off control, the PT4120/4140 series of DC-DC converters incorporate a remote on/off function. This function may be used in applications that require battery conservation, power-up/shut-down sequencing, and/or to co-ordinate the power-up of the regulator for active in-rush current control. (See the related application note, AN21).

This function is provided by the *Remote On/Off* control, pin 1. If pin 1 is left open-circuit, the converter provides a regulated output whenever a valid source voltage<sup>4</sup> is applied between +V<sub>in</sub>(pin 3), and -V<sub>in</sub>(pin 2). Applying a low-level ground signal<sup>2</sup> to pin 1 will disable the regulator output<sup>6</sup>.

Table 1 provides details of the threshold requirements for Remote On/Off pin. Figure 1 shows how a discrete MOSFET (Q<sub>1</sub>)<sup>5</sup>, may be referenced to the negative input voltage rail and used with this control input.

**Table 1 Inhibit Control Thresholds<sup>2</sup>**

Parameter	min	max
Enable (V <sub>IH</sub> )	2.5V	(Open Circuit) <sup>5</sup>
Disable (V <sub>IL</sub> )	-0.3V	0.8V

#### Notes:

- The functionality of the remote on/off control logic is similar to the inhibit control described with other Power Trends regulators, but the flexibility and threshold tolerances will be different. For specific information on other converters, consult the applicable application note.
- The on/off control uses -V<sub>in</sub> (pin 2), the primary side of the converter as its ground reference. All voltages specified are with respect to -V<sub>in</sub>.
- The on/off control internal circuitry is a high impedance 10µA current source. The open-circuit voltage may be as high as 8.3Vdc.
- The PT4120/40 series incorporates an “Under Voltage Lockout” (UVLO) function. This function automatically inhibits the converter output until there is sufficient input voltage for the converter to produce a regulated output. Table 2 gives the applicable UVLO thresholds.

**Table 2 UVLO Thresholds<sup>2/</sup>**

Series	UVLO Threshold	V <sub>in</sub> Range
PT4120	31V Typical	36 – 75V
PT4140	15V Typical	18 – 40V

- The Remote On/Off input of the PT4120/40 series regulators is most ideally controlled with an open-collector (or open-drain) discrete transistor or MOSFET. *Do not* use a pull-up resistor.
- When the converter output is disabled, the current drawn from the input supply is typically reduced to 8mA (16mA maximum).

- Keep the on/off transition to less than 1ms. This prevents erratic operation of the ISR, whereby the output voltage may drift un-regulated between 0V and the rated output during power-up.

**Figure 1**

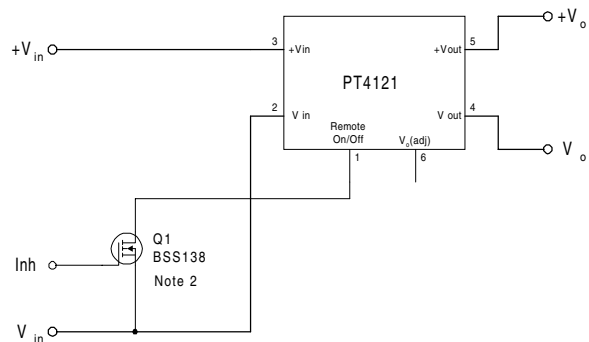

**Turn-On Time:** The converter typically produces a fully regulated output voltage within 50-ms after the application of power, or the removal of the low voltage signal from the Remote On/Off pin. The actual turn-on time will vary with the input voltage, output load, and the total amount of capacitance connected to the output. Using the circuit of Figure 1, Figure 2 shows the typical output voltage and input current waveforms of a PT4121 after Q<sub>1</sub> is turned off at time t = 0s. The waveform was measured with a 48Vdc input voltage, and 4A resistive load.

**Figure 2**

